



P815



Bi-amplified L/C/R Speaker

Technical Specifications



- Main speaker for large to very large rooms, up to and including small cinemas
- Recommended for rooms 25 to 50 feet in depth
- THX Approved for integration into professional rooms, including THX Certified Screening Rooms and THX pm3 Studios
- 1.5" compression driver on elliptical constant directivity waveguide: 80°H x 50°V from 1.5 kHz
- 8" high-output midrange with 2.5" voice coil
- 15" woofer with 3" voice coil
- Identical Voice™ timbre-matched to Procella P5, P6, P8, P610, P28 and P860
- Sealed box design
- Shallow depth (11.0" / 280mm deep)
- 600W (P8) + 600W (P15Si) when external Procella DA-06 power amplifier is used
- DA-06 amp provides DSP control for room placement conditions including baffle wall and free standing

Frequency response

-3dB points 40Hz and 20kHz

Maximum SPL

free-standing 122dB continuous, 126dB peak
in baffle wall 126dB continuous, 132dB peak

Components

Low (P15Si) 15" driver with 75mm voice coil in 92 litre sealed box
Midrange (P8) 8" high output driver with 40mm (1.5") voice coil in 15 litre sealed box
High Frequency (P8) 1.5" compression driver, Polyester diaphragm, on elliptical constant directivity waveguide

Impedance

Low (P15Si) 8 ohms nominal
Mid/High (P8) 8 ohms nominal

Power Handling

Low (P15Si) 700W continuous, 1,500W peak
Mid/High (P8) 250W continuous, 1,000W peak

Sensitivity

1m/1W 96 dB

Dispersion pattern

-6dB Constant directivity:
80°H x 50°V from 1.5kHz

Crossover

4th Order Linkwitz-Riley ,
1.6 kHz and 150Hz

Connectivity

2 pair gold-plated binding posts

Construction

Void free MDF internally cross braced
Semi matte textured black paint finish

Dimensions

HxWxD 40.6" x 18.9" x 11.0"
1030 x 480 x 280 mm

Net weight

121 Lbs / 55 Kg

Shipping Cartons (2) and Weight

P8 HxWxD 19.75" x 23.5" x 12" / 37.2 lbs.
500 x 585 x 305 mm / 16.9 Kg
P15Si HxWxD 23.6" x 27.6 x 17.7" / 88 lbs.
600 x 700 x 450mm / 40 Kg

Included

Connecting Bracket, Damper feet,
Protective grilles

Assembly

Sweden; 100% QC testing

DA-06 Power Amplifier

Sold and packaged separately.
See DA-05 / DA-06 Tech Sheet.

Power

600W (P8) + 600W (P15Si)
continuous, Class D

DSP Settings

Free standing, Against wall,
User selectable In baffle wall, In baffle wall with
compensation EQ for perf screen

P815

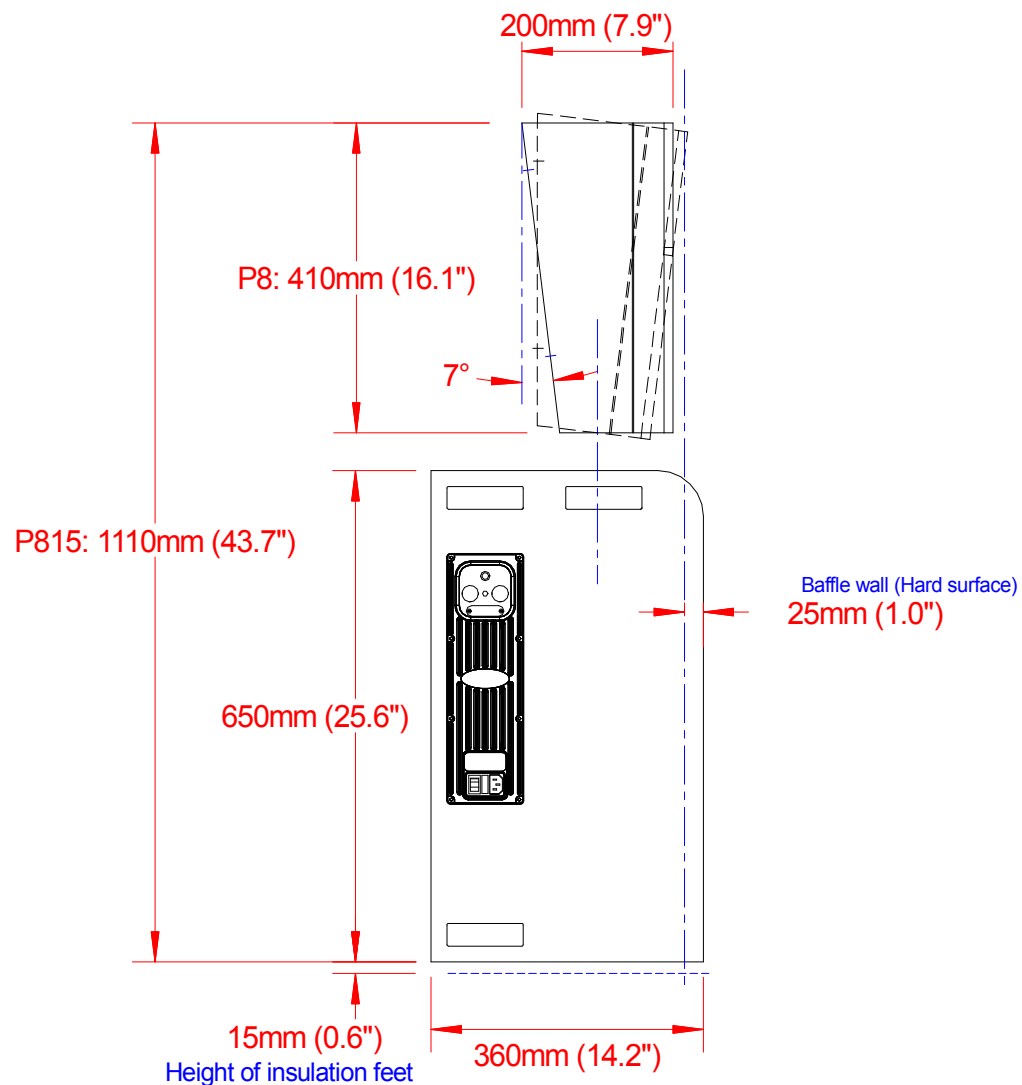
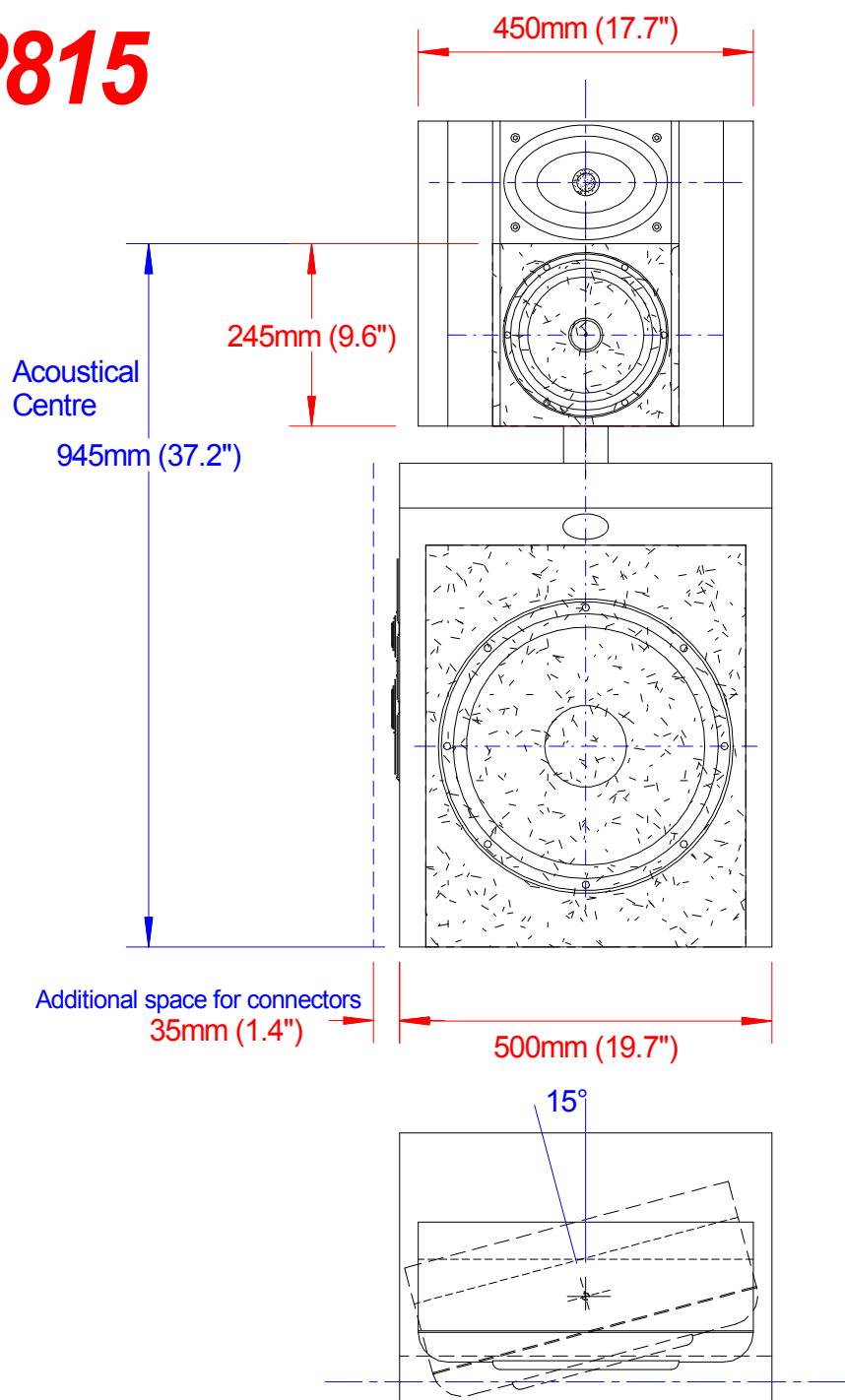

Baffle wall cut-out for P8 = 480 x 440mm (19-3/4" x 17-3/8")
P815LF = 700 x 540mm (27-1/2" x 21-1/4")
P815 = 1160 x 540mm (45-5/8" x 21-1/4")
Weight P8 = 15.5kg (34.2Lbs)
P815LF = 48kg (106Lbs)



Procella P815 dimensions
P815_vue.CAD
Anders Uggelberg aug -09
UPD:16/9, 23/7-11, 26/1 -12
Scale 1:10 (PDF/JPG-file not to scale)